



## Features

- 20000 counts manual type DMM with LCD display
- 100L LQFP package
- 3V DC power supply
- ADC Conversion rate : 2.8 times/s for V/R modes
- Manual type measurement
  - \* Voltage measurement :  
200mV/2V/20V/200V/ 1000V
  - \* Current measurement :  
200u/2000u/20m/200m/20A
  - \* Resistance measurement :  
200/2K/20K/200K/2M/ 20M/200MΩ
  - \* Conductance measurement :200.00nS
  - \* Capacitance measurement:  
20n/200n/2u/20u/200u/2m/20m/200mF
  - \* Non-contact AC electric field detection
  - \* Diode voltage measurement
  - \* Continuity check
- Auto frequency measurement mode  
200.00Hz ~ 60.00MHz auto range
- Duty Cycle measurement  
5% - 95% (F < 10kHz)
- Hazardous AC/DC voltage (HV) indication
- 5 ADP modes for extension application
- Temperature mode with internal scale translation circuit from °C to °F (1°C resolution)
- K-type thermocouple reference table compensation (-200 ~ 1350°C range)
- Push functions:
  - \* MAX/MIN
  - \* VAHz mode
  - \* PEAK Hold mode
  - \* Relative mode
  - \* KEY function (AC/DC or °C/°F swap function)

- \* LPF function for ACV/ACA mode
- \* Data Hold & Backlight function
- Band-gap reference voltage output
- Current mode overflow selection (10A or 20A)
- Voltage mode overflow selection  
( DC / AC: 1010V, DC / AC : 1010/760V)
- LCD segment check when power on
- Auto power off (15/ 30min idle time)
- Sleep state indicative signal output
- Re-power on
- On-chip buzzer driver
- Low battery detection

## ■ Description

ES289B is an integrated analog-to-digital converter with 20000-count LCD, manual type DMM IC which is operated 3V DC power supply. Automatic range selection is provided for frequency measurement only. It could support AC/DC voltage measurement, resistance measurement, capacitance measurement, and AC/DC current measurement. Expensive and bulky mechanical range switches are not required. Other features include LPF function, data holding, maximum and minimum value holding, diode measurement, temperature measurement, continuity checking, low battery detection, auto power off, re-power on, backlight driver and buzzer driver.

## Application

- Manual type digital multimeter
- Manual type clamp meter

Pin Assignment

- 100L LQFP package

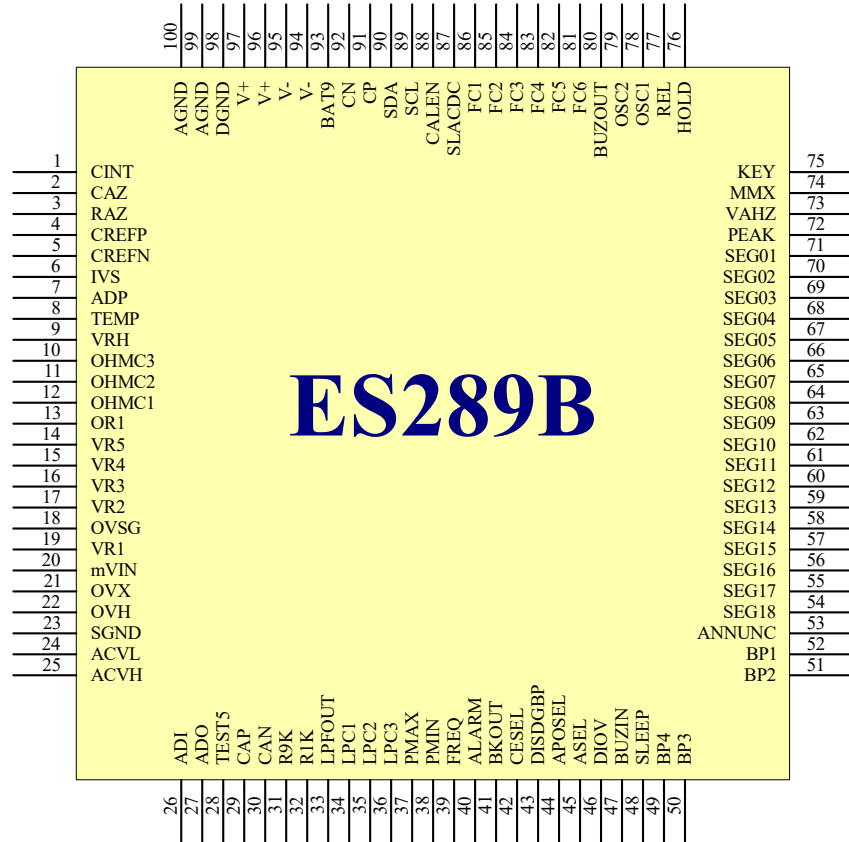



**Pin Description**

Pin No	Symbol	Type	Description
1	CINT	O	High-resolution integrator output. Connect to integrate capacitor. (Metalized Polypropylene Film Capacitor type is recommended)
2	CAZ	O	High-resolution auto-zero capacitor connection.
3	RAZ	O	Buffer output pin in AZ and ZI phase.
4	CREFP	O	Positive connection for reference capacitor of A/D.
5	CREFN	O	Negative connection for reference capacitor of A/D.
6	IVS	I	Measurement input in Current mode.
7	ADP	I	Measurement input in ADP mode.
8	TEMP	I	Measurement input in Temp mode.
9	VRH	O	Output of band-gap voltage reference. Typically -1.22V.
10	OHMC3	O	Filter capacitor connection for resistance mode.
11	OHMC2	O	Filter capacitor connection for resistance mode.
12	OHMC1	O	Filter capacitor connection for resistance mode.
13	OR1	O	Reference resistor connection for 200.00Ω range
14	VR5	O	Voltage measurement ÷10000 attenuator(1000V)
15	VR4	O	Voltage measurement ÷1000 attenuator(200.00V)
16	VR3	O	Voltage measurement ÷100 attenuator(20.000V)
17	VR2	O	Voltage measurement ÷10 attenuator(2.0000V)
18	OVSG	O	Sense low voltage for resistance/voltage measurement
19	VR1	I	Voltage measurement Input. Connect to an accurate 10MΩ resistor.
20	mVin	I	Measurement input in 200.00mV mode.
21	OVX	I	Sense input for resistance / capacitance measurement.
22	OVH	O	Output connection for resistance measurement.
23	SGND	I	Signal Ground input.
24	ACVL	I	Rectified signal low input in ACV/ACA mode. Connect to negative output of external AC to DC converter.
25	ACVH	I	Rectified signal high input in ACV/ACA mode. Connect to positive output of external AC to DC converter.
26	ADI	I	Negative input of internal AC to DC OP Amp.
27	ADO	O	Output of internal AC to DC OP Amp.
28	TEST5	O	Buffer output of OVSG.
29	CAP	O	Positive auto-zero capacitor connection for capacitor measurement.
30	CAN	O	Negative auto-zero capacitor connection for capacitor measurement.
31	R9K	O	Connect to a precise 9KΩ resistor for capacitor measurement.
32	R1K	O	Connect to a precise 1KΩ resistor for capacitor measurement.
33	LPFOUT	O	Capacitor C1 connection for internal low-pass filter
34	LPC1	O	Capacitor C1 connection for internal low-pass filter
35	LPC2	O	Capacitor C2 connection for internal low-pass filter



**Pin Description ( Continued )**

Pin No	Symbol	Type	Description
36	LPC3	O	Capacitor C3 connection for internal low-pass filter
37-38	PMAX/PMIN	O	Connected to Peak-hold capacitor
39	FREQ	I	Frequency counter input, offset V-/2 internally by the chip.
40	ALARM	O	HV signal detection in Voltage mode and EF mode indication output.
41	BKOUT	O	Push Hold key lager than 2 sec. to enable the back light function. This pin will change from V- to V+ and lasts for 5 minutes.. Once press Hold key lager than 1 sec. again , this pin will change level back to V-.
42	CESEL	I	Voltage OL selection feature control pin. (1010V/610V)
43	DISDGBP	I	Control warning buzzer output at HV mode. Pulled to low and buzzer is disabled.
44	APOSEL	I	Auto power off idle time selection
45	ASEL	I	Current mode OL indication for 20A current mode
46	DIOV	I	Pulled to V- to set the 2.8V OL level in diode mode measurement
47	BUZIN	I	Pulled to V- to enable the buzzer output (BUZOUT) always.
48	SLEEP	O	Sleep mode indicator, asserts low in SLEEP mode.
49-52	BP4-1	O	LCD backplane 4 - LCD backplane1
53	ANNUNC	O	RS232 TX (baud 9600bps).
54-71	SEG18 - SEG01	O	LCD segment line 01 – 18.
72	PEAK	I	Pulse to V- to enable PMAX/PMIN function
73	VAHz	I	Pulse to V- to enable VAHz function
74	MMX	I	Pulse to V- to enable MAX/MIN function.
75	KEY	I	Pulse to V- to change mode.
76	HOLD	I	Pulse to V- less than 1 second. to enable HOLD function.
77	REL	I	Pulse to V- to enable Relative function.
78-79	OSC1-2	O	Connect to 4MHz crystal oscillator
80	BUZOUT	O	Outputs a 2KHz audio frequency signal for driving piezoelectric buzzer
81	FC6	I	Switch 6 for function selection.
82	FC5	I	Switch 5 for function selection.
83	FC4	I	Switch 4 for function selection.
84	FC3	I	Switch 3 for function selection.
85	FC2	I	Switch 2 for function selection.
86	FC1	I	Switch 1 for function selection.
87	SLACDC	I	Select initial DC/AC state.
88	CALEN	I	Pulled to V- to enter calibration mode
89	SCL	I	Output to EEPROM 24LC02 clock.
90	SDA	I/O	Input / Output from to EEPROM 24LC02 data. Open drain output.



**Pin Description ( Continued )**

Pin No	Symbol	Type	Description
91	CP	O	Positive capacitor connection for on-chip DC-DC converter.
92	CN	O	Negative capacitor connection for on-chip DC-DC converter.
93	BAT9	I	Low battery configuration. If 3V battery is used, connect it to DGND. The default low-battery threshold voltage is -2.3V. If 9V battery is used, the low battery enunciator is displayed when the voltage of this pin is less than VRH (-1.2V)
94	V-	P	Negative supply voltage.
95	V-	P	Negative supply voltage.
96	V+	O/P	Output of on-chip DC-DC converter.
97	V+	O/P	Output of on-chip DC-DC converter.
98	DGND	P / G	Digital ground.
99	AGND	P / G	Analog ground.
100	AGND	P / G	Analog ground.



### Absolute Maximum Ratings

Characteristic	Rating
Supply Voltage (V- to AGND)	-4V
Analog Input Voltage	V- -0.6 to V+ +0.6
V+	V+ $\geq$ (AGND/DGND+0.5V)
AGND/DGND	AGND/DGND $\geq$ (V- -0.5V)
Digital Input	V- -0.6 to DGND +0.6
Power Dissipation. Flat Package	500mW
Operating Temperature	-20°C to 70°C
Storage Temperature	-45°C to 125°C

### Electrical Characteristics

T<sub>A</sub>=23°C

Parameter	Symbol	Test Condition	Min.	Typ.	Max	Units
Power supply	V-	Regulated	2.7	-3.0	3.3	V
Operating supply current In DCV mode	I <sub>DD</sub>	Normal operation	—	2.8	3.2	mA
	I <sub>SS</sub>	In sleep mode	—	—	10	μA
Voltage roll-over error	REV	10MΩ input resistor	—	—	±0.1	%F.S <sup>1</sup>
Voltage nonlinearity	NLV	Best case straight line CIL=MPR capacitor	—	—	±0.1	%F.S <sup>1</sup>
Zero input reading		10MΩ input resistor	-000	000	+000	counts
Band-gap reference voltage	V <sub>RH</sub>		-1.26	-1.22	-1.18	V
Open circuit voltage for 200Ω measurement		V-=3V	—	-3.0	—	V
Open circuit voltage for other Ω measurement			-1.19	-1.08	-0.97	V
Open circuit voltage for $\bar{U}$ measurement			—	-1.025	—	V
Peak to peak backplane voltage	V <sub>LCD</sub>	-3.5V ≤ V- ≤ -2.2V	3.0	3.1	3.2	V
Low battery flag voltage		V- to AGND (LBAT9 connected to GND)	-2.4	-2.3	-2.2	V
Internal pull-high to 0V current		Between V- pin and HOLD, KEY, REL FC1-FC6, MMX	—	1.2	—	μA
AC frequency response at 2.0000V range		±1%	—	40-400	—	HZ
		±5% (No compensated)	—	400-2000	—	
3dB frequency for LPF <sup>2</sup> active	f <sub>3dB</sub>	3dB=Full (ADP)	—	1	—	kHz
Capacitance measurement accuracy		20nF – 200uF	-2.5	—	2.5	%
			-3	—	3	counts
Capacitance measurement accuracy		2mF – 200mF	-3.5	—	3.5	%
			5	—	5	counts
Reference voltage temperature coefficient	TC <sub>RF</sub>	-20°C < T <sub>A</sub> < 70°C	—	—	50	ppm/°C

Note:

1. Full Scale.
2. ES289B built-in 3<sup>rd</sup> order low pass filter available for AC mode

## Function Description

### 1. Operating Modes

#### 1.1. Semi-auto calibration scheme

ES289B includes DMM meter features in single chip. DMM manufacturers need the calibration process in production. The traditional solution needs the variable resistors for calibration by manual adjustment. ES289B provide another calibration scheme and the most variable resistors could be ignored. When ES289B is at OFF-state, pull *CALEN* (pin 88) to V- to active the calibration scheme after re-power on. When semi-auto calibration scheme is active, use **HOLD** key to increase the counts on display and use **MMX** key to decrease the counts on display. The adjustment step is approximate three counts. If coarse adjustment is required, push **HOLD** and **MMX** more than one second to speed up to approximate 50 counts per second. After calibration process is finished, push **HOLD** and **MMX** simultaneously less than 1 second to save the digital controlled code to external EEPROM (24LC02).

The semi-auto calibration scheme supports the following 19 measurement modes. When *CALEN* pin is active, set the proper function switches or push KEY to choose the target measurement mode. When mode is selected, the LCD segment of Unit of related measurement will be blinking.

Mode	Default Range For CAL	Remark
Voltage Measurement	2.0000V-1000V (DC separated)	ACV 20V-1000V use the same configuration of ACV 2V range.
	ACV 2V range	
mV Voltage Measurement	200.00mV (DC/AC separated)	
DC Current Measurement For Multi-meter (uA/mA)	2000.0uA/200.00mA	Other range use the same configuration.
AC Current Measurement For Multi-meter (uA/mA)	AC 2000.0uA / 200.00mA	Select lower range for calibration in AC mode. Higher range calibration use the same as ACV mode.
AC/DC Current Measurement For Multi-meter (A)	20A	Auto 2 ranges choose one, proposed to use a large range to calibration.
Capacitor Measurement	200.00nF	2 ranges separated for calibration
Temperature Measurement	1000.0°C	Lower range in auto temperature measurement.
ADP Measurement	20000 / 2000.0 / 200.00 / 20.000/2.0000	5 ranges separated for calibration.

After calibration procedure is finished, set ES289B to OFF-state and set *CALEN* (pin88) to DGND or kept floating to return to normal mode operation after re-power on.

## 1.2. Voltage Measurement

A re-configurable voltage divider provides a manual range in voltage measurement mode. The 200.00mV range is independent and manual mode. It takes input signal from *mVin* (pin20). The other ranges take the input signal from *VRI* (pin19). The low input from pin *SGND*. The following table summarizes the Full-Scale ranges in each configuration.

Configuration	Full Scale Range	Divider Ratio	Resister Connection	Input Pin
<b>VRange1</b>	200.00mV	1	-	<i>mVin</i> V.S. <i>SGND</i>
<b>VRange2</b>	2.0000V	1/10	VR2 (1.111MΩ)	<i>VRI</i> V.S. <i>SGND</i>
<b>VRange3</b>	20.000V	1/100	VR3 (101KΩ)	<i>VRI</i> V.S. <i>SGND</i>
<b>VRange4</b>	200.00V	1/1000	VR4 (10.01KΩ)	<i>VRI</i> V.S. <i>SGND</i>
<b>VRange5</b>	1000.0V	1/10000	VR5 (1KΩ)	<i>VRI</i> V.S. <i>SGND</i>

The ES289B support the hazardous live voltage warning. When the voltage measured exceeds the 30V, the buzzer generates 2KHz beep and *ALARM* (pin40) drive high output (V+ level) periodically. It can remind the user to notice the hazardous voltage. The buzzer sound warning could be cancelled by *DISDGBP* (pin43).

### 1.2.1. Low Pass Filter (LPF) Mode For ACA/ACV Mode

ES289B provides a 3<sup>rd</sup> order low-pass filter to reduce the influence of high frequency noise. This LPF feature is available in ACV or ACA modes. Set *FC5* to low in these modes, the **KEY** button is used to activate the LPF feature. Press **KEY** button for less than 1 second to select the 3dB bandwidth of LPF sequentially ( Full/ 1kHz ) and the relative LCD symbol on LCD panel will be active also.

### 1.2.2. OL Selection

ES289B has a voltage OL selection feature archived by configuring the pin *CESEL* (pin42). In 1000V voltage mode, ES289B will show OL when the voltage is exceed the overflow level. If *CESEL* is connected to DGND, ES289B will have a 1010V overflow level in voltage mode. If *CESEL* connected to V-, the overflow level will be set to 610V in DCV and ACV mode. The configuration of *CESEL* is listed below.

**For ACV/DCV voltage modes:**

	<i>CESEL</i>		
	V-	DGND	Floating
<b>DCV</b>	<b>610V</b>	<b>1010V</b>	<b>1010V</b>
<b>ACV</b>	<b>610V</b>	<b>1010V</b>	<b>760V</b>



### 1.3. Current Measurement For Multi-meter

ES289B has 5 manual current measurement modes for multi-meter. The following table summarizes the full-scale range of each mode. When ES289B operates in the current measurement modes for multi-meter, it takes high input from pin *IVS* (pin6), low input from pin *SGND*.

Mode	FC6	FC1~4	Full Scale	Input Terminal
200.00uA	0	0,0,0,1	20.000mV	<i>IVS</i> <i>V.S.</i> <i>SGND</i>
2000.0uA	1	0,0,0,1	200.00mV	<i>IVS</i> <i>V.S.</i> <i>SGND</i>
20.000mA	0	1,0,0,0	20.000mV	<i>IVS</i> <i>V.S.</i> <i>SGND</i>
200.00mA	1	1,0,0,0	200.00mV	<i>IVS</i> <i>V.S.</i> <i>SGND</i>
20.000A <sup>1</sup>	1	0,0,0,0	200.00mV	<i>IVS</i> <i>V.S.</i> <i>SGND</i>

Note:

1. Connect *ASEL* (pin45) to V- will set maximum readings of input for 20.00A mode to 10.00A.

### 1.4. Resistance Measurement

A re-configurable divider provides a manual Full-Scale range in resistance measurement mode.

The following table summarizes the full-scale ranges and the reference resistors in each configuration.

Configuration	Full Scale Range	Relative Resistor	Equivalent value
OR1	200.00Ω	OR1	100Ω
OR2	2.0000KΩ	VR5	1KΩ
OR3	20.000KΩ	VR4    VR1	10KΩ
OR4	200.00KΩ	VR3    VR1	100KΩ
OR5	2.0000MΩ	VR2    VR1	1MΩ
OR6	20.000MΩ	VR1	10MΩ
OR7	200.0MΩ	VR1	10MΩ

The ES289B also support conductance measurement. It shares the same configuration with 10MΩ. The maximum displayed count is 20000 and the resolution should be 0.01nS.

Mode	SLACDC	FC1~5	Full Scale Range	Relative Resistor	Equivalent value
Conductance	0	1,0,1,1,x	200.00nS	VR1	10MΩ

### 1.5. Capacitance Measurement

The following table summarizes the eight ranges of capacitance measurement mode.

Configuration <sup>1</sup>	Full Scale Range	Relative Resistor	Measurement Period
C1 <sup>3</sup>	20.000nF	Ratio to C2	0.35 sec
C2 <sup>2</sup>	200.00nF	CAL	0.35 sec
C3	2.0000uF	Ratio to C2	0.35 sec
C4	20.000uF	Ratio to C2	0.7 sec (max)
C5	200.00uF	Internal matching	0.7 sec (max)
C6	2.0000mF	Internal matching	3.5 sec(max)
C7	20.000mF	Internal matching	7 sec(max)
C8	200.00mF	Internal matching	35 sec(max)

Note:

1. In order to obtain an accurate reading, a capacitor must be discharged before measurement begins. The chip has a built-in discharge mode to automatically discharge the capacitor. In discharge mode, the main-display shows **dIS.C**. Discharging through the chip is quite slow. We recommend users to discharge the capacitor with some other apparatus.
2. The C2 range is calibrated in calibration scheme.
3. The C1 range residual offset could be compensated by the small capacitors near to OVH pin.

### 1.6. Continuity Check

Continuity check shares the same configuration with 200.00Ω manual resistance measurement mode and has buzzer output to indicate continuity. The buzzer generates 2KHz beep and *ALARM* (pin 40) drive high output (V+ level) whenever the reading is less than 30Ω. The ES289B built in a high speed short detection circuit and the detection period could be less than 10ms.

### 1.7. Diode Measurement

Diode measurement mode shares the same configuration with 2.0000V manual voltage measurement mode and has buzzer output to indicate continuity. The buzzer generates a 2KHz sound and *ALARM* (pin 40) drive high output (V+ level) whenever the reading is less than 30mV. The source output voltage is the same as V+ terminal. If the test circuit is open or the voltage drop between the two ports of the diode under test is larger than 2V or 2.8V (depends on *DIOV* pin level), the LCD panel will show “OL”.

	<i>DIOV</i> (pin46)	
	DGND/Floating	V-
OL	2.000V	2.800V

The ES289B also support a LED forward voltage measurement mode. It is necessary to use external source to achieve the measurement. The following table & diagram summarizes the diode & LED measurement mode.

Mode	SLACDC	FC1~5	Full Scale	Input Terminal
LED	1	1,0,1,1,X	3.50V	<i>VR1</i> V.S. <i>SGND</i>

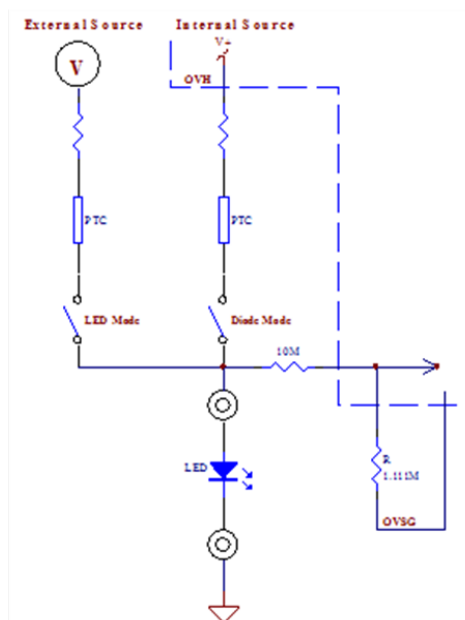

### 1.8. Frequency Counter

The time base of the frequency counter is derived from an external crystal oscillator by

$$T_{\text{counter}} = \frac{20000,000}{F_{\text{osc}}}$$

Where  $F_{\text{osc}}$  is the frequency of the crystal oscillator. Thus, the counter has a 1-second time base when a 4MHz oscillator is used. The frequency counter can select the proper range automatically or manually. Auto-range operation extends over six decades, from 200.00Hz to 20.000MHz. The following table summarizes the Full-Scale range of the frequency counter.

Range	Full Scale
FR1	200.00Hz
FR2	2.0000KHz
FR3	20.000KHz
FR4	200.00KHz
FR5	2.0000MHz
FR6	20.000MHz
FR7	60.00MHz

\*If input frequency is less than 1.00Hz, ES289B will show **0.00**

### 1.9. Duty Cycle Measurement

When frequency mode is selected, push **VAHz** key to enter duty cycle measurement. The duty cycle mode range is within 5.0% to 95.0% (< 10kHz@3Vpp). The minimum resolution is 0.1%. If the source frequency duty cycle is smaller than 5.0%, the UL will be shown on the LCD display. If the duty cycle is larger than 95.0%, the OL will be shown on the LCD. When the frequency is zero, the duty cycle display will be 0.0% or “UL” shown.

If **VAHz** key is not available, set FC mode could select the duty cycle mode also.

Mode	FC1~4	SLACDC / FC6	Range	Input Terminal
Duty cycle	0,1,1,1	0,0	5% - 95%	FREQ V.S. SGND

### 1.10. Electrical field detection mode (NVC)

ES289B supports a non-contact AC voltage measurement, which is called electric field measurement also. The ADC input is configured from *ADP* pin vs. *SGND*. When no or less electric field is detected, the LCD display shows “EF”. If the electric field is detected, the strength will be showed on the LCD display by “-“ not digits type. Level 1 (equivalent to 12.5% full scale of ADC) is “-“ and the level 4 (equivalent to 100% full scale of ADC) is “----“. Additional beeper (*BUZOUT* pin) and LED alarm (*ALARM* pin) will be output from ES289B. The frequency of buzzer and LED alarm depends on the strength of electric field also. The Faster beeper means the stronger electric field (AC voltage) is sensed. The input voltage is taken from *ADP* (pin7).

Mode	FC1~4	SLACDC / FC6	Full Scale	Input Terminal
EF	0,1,1,0	1,1	-	<i>ADP V.S. SGND</i>

EF test circuit

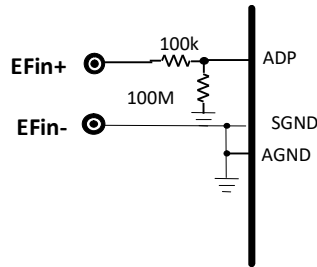

### 1.11. Temperature Measurement mode

Temperature measurement mode takes input signal from *TEMP* pin (pin8). The ES289B has °C to °F scale translation circuit and standard K-type thermocouple reference table is built-in. External cold-junction compensation circuit is still necessary.

Mode	FC1~4	SLACDC / FC6	Range	Input Terminal
°C	0,1,0,0	0,1	-200.0 °C ~ 1350.0 °C	<i>TEMP V.S. SGND</i>
°F	0,1,0,0	1,1	-328.0 °F ~ 1999.9 °F	

### 1.12. ADP

ES289B provides 5 manual range ADP measurement modes for user define. The *ADP* pin(pin7) is auxiliary input terminal for ADC of ES289B. The full scale for ADP mode is 200.00mV. If FC5 is pulled to V-, the minus sign will not be shown on LCD segment.

Mode	FC1~4	SLACDC / FC6	Full Scale	Input Terminal
<b>ADP0</b>	1,0,0,1	1,1	20000	<i>ADP V.S. SGND</i>
<b>ADP1</b>	0,0,1,1	1,1	2000.0	<i>ADP V.S. SGND</i>
<b>ADP2</b>	0,0,1,0	1,1	200.00	<i>ADP V.S. SGND</i>
<b>ADP3</b>	0,1,0,1	1,1	20.000	<i>ADP V.S. SGND</i>
<b>ADP4</b>	0,1,1,1	1,0	2.0000	<i>ADP V.S. SGND</i>

**Note:** If FC5 is set to V-, the minus sign will be disabled.

### 1.13. Auto Power Off (APO)

ES289B has a default auto power off function. If the meter is idle for more than the given idle time duration, the chip automatically turns the power off. When *APOSEL* (pin44) is set to V-, the idle time to trigger the auto power off function is set to 30 minutes. When *APOSEL* is floating, the idle time is 15 minutes. When APO is occurred, the state of the meter is reserved. The APO symbol on the LCD panel indicates whether the auto power off is enabled or not. In some cases, user might want to disable Auto power off. There are two ways to disable this feature as following:

1. Power on the meter when any of the push functions, except for **HOLD**, is pressed down.

**Note:** Powering on the meter while pressing **HOLD** and lasts 2 seconds turns on all LCD segments until **HOLD** is pressed again.

### 1.14. Sleep

The meter enters sleep mode after auto power off. The *SLEEP* pin (pin48) asserts low (V-) in the sleep mode, and asserts high (V+, not 0V) after re-power on.

### 1.15. Re-Power On

After auto power-off, pushing any of the push function or changing the rotary mode can turn on the meter again. If the meter is re-powered on by changing the rotary mode, the stored state is cleared. If the meter is re-powered on by push functions, the chip restores the stored state and enters **HOLD** mode. The LCD displays the stored value.



### 1.16. Hazardous Voltage Indication

The ES289B could provide the AC/DC hazardous voltage indication for voltage/resistor/ diode modes. Of course, the indication could support LCD symbol /LED /Buzzer driving simultaneously. Especially ES289B could detect the AC voltage in DCV mode and detects the DC voltage in ACV mode. It means if not proper AC or DC voltage signal exists on the DUT when DCV or ACV measurement mode is set, the HV indication will be still active.

#### HV indication criterion

Function / Range	DC voltage (typ.)	AC voltage (typ.)
AC mV	> $\pm 3V$	OL
AC 4V	> $\pm 20V$	OL
AC 40V – 1000V	> $\pm 100V$	> 30Vrms
DC mV	OL	> 3Vrms (40-1kHz)
DC 4V	OL	> 20Vrms (40-1kHz)
DC 40V-1000V	> $\pm 30V$	> 90Vrms (40-1kHz)
Freq. mode	> $\pm 40V$	> 30Vrms (40-1kHz)
Res/Diode modes	> $\pm 10V$	> 10Vrms (40-1kHz)

**Note: If AC+DC signal is applied, the voltage criterion will be changed.**

### 1.17. Low Battery Voltage Detection

ES289B provides a voltage detection input (pin 93: *BAT9*) for non-3V battery application. When *BAT9* is less than *VRH* terminal voltage, the LCD segment of low battery will appear. When the Low battery status lasts for 10 seconds, the LCD segment of low battery will be blinking. When the symbol is blinking for 20 seconds, the operation of meter will be inhibited and LCD panel will show “Lo.bt”. In this case, it is suggested to replace a new battery immediately. After “Lo.bt” appears and lasts for 60 seconds, ES289B will enter to auto power off mode.

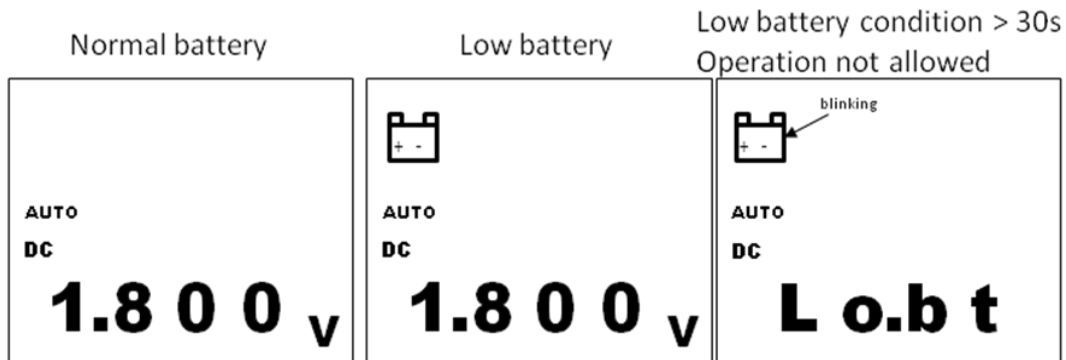

Low battery test (9V)

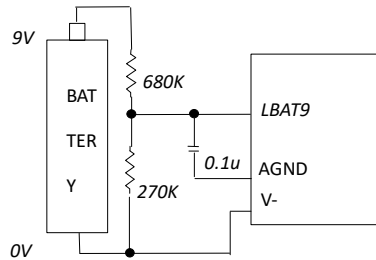



## 2. Measurement Mode Switching

Measurement mode depends on the logic level of *SLACDC*, *FC1*, *FC2*, *FC3*, *FC4*, *FC5*, *FC6* and **KEY** selection. When *FC5/FC6* is logic high (kept floating), the measurement mode list is shown below:

<i>SLACDC</i>	<i>FC1</i>	<i>FC2</i>	<i>FC3</i>	<i>FC4</i>	Mode	<b>KEY</b> selection
0	1	0	1	1	DC 200.00V	DCV ↔ ACV
0	1	1	0	1	DC 20.000V	DCV ↔ ACV
0	1	1	1	1	DC 200.00mV	DCmV ↔ ACmV
0	1	1	1	0	DC 2.0000V	DCV ↔ ACV
0	0	0	0	0	DC 20.00A <sup>2</sup>	DCA ↔ ACA
0	1	1	0	0	20.000 MΩ	----
0	1	0	0	0	DC 200.00mA <sup>2</sup>	DCmA ↔ ACmA
0	1	0	1	0	2.0000 MΩ	----
0	1	0	0	1	200.00 kΩ	----
0	0	0	1	1	200.00 Ω	----
0	0	0	0	1	DC 2000.0 uA <sup>2</sup>	DCuA ↔ ACuA
0	0	1	1	1	DC 1000.0V	DCV ↔ ACV
0	0	0	1	0	Frequency mode (AUTO)	----
0	0	1	1	0	2.0000 kΩ	----
0	0	1	0	0	1350 °C	°C ↔ °F
0	0	1	0	1	20.000 kΩ	----
1	1	0	1	1	AC 200.00V	ACV ↔ DCV
1	1	1	0	1	AC 20.000V	ACV ↔ DCV
1	1	1	1	1	AC 200.00mV	ACmV ↔ DCmV
1	1	1	1	0	AC 2.0000V	ACV ↔ DCV
1	0	0	0	0	AC 20.00A <sup>2</sup>	ACA ↔ DCA
1	1	1	0	0	Continuity mode	Continuity ↔ Diode
1	1	0	0	0	AC 200.00mA <sup>2</sup>	ACmA ↔ DCmA
1	1	0	1	0	Diode mode	Diode ↔ Continuity
1	1	0	0	1	ADP0 (±20000) <sup>1</sup>	----
1	0	0	1	1	ADP1 (±2000.0) <sup>1</sup>	----
1	0	0	0	1	AC 2000.0 uA <sup>2</sup>	ACuA ↔ DCuA
1	0	1	1	1	AC 1000.0V	ACV ↔ DCV
1	0	0	1	0	ADP2 (±200.00) <sup>1</sup>	----
1	0	1	1	0	EF mode	----
1	0	1	0	0	2462 °F	°F ↔ °C
1	0	1	0	1	ADP3 (±20.000) <sup>1</sup>	----

Note:

1. When *FC5* is high, the ADP0, ADP1, ADP2, ADP3 and ADP4 modes can display minus sign.
2. These modes could be designed for multimeter current modes, please refer to section 1.2.



### Measurement Mode Switching (Continued)

Measurement mode depends on the logic level of *SLACDC*, *FC1*, *FC2*, *FC3*, *FC4*, *FC5* and **KEY** selection. When *FC5* is low (pulled to V-), the **KEY** function is disabled in most modes. The measurement mode list is shown below: (Note: *FC6* is high)

<i>SLACDC</i>	<i>FC1</i>	<i>FC2</i>	<i>FC3</i>	<i>FC4</i>	Mode	<b>KEY</b> selection & Remaks
0	1	0	1	1	DC 200.00V	----
0	1	1	0	1	DC 20.000V	----
0	1	1	1	1	DC 200.00mV	----
0	1	1	1	0	DC 2.0000V	----
0	0	0	0	0	DC 20.00A <sup>2</sup>	----
0	1	1	0	0	20.000 MΩ	----
0	1	0	0	0	DC 200.00mA <sup>2</sup>	----
0	1	0	1	0	2.0000 MΩ	----
0	1	0	0	1	200.00 kΩ	----
0	0	0	1	1	200.00 Ω	----
0	0	0	0	1	DC 2000.0 uA <sup>2</sup>	----
0	0	1	1	1	DC 1000V	----
0	0	0	1	0	Frequency mode (AUTO)	----
0	0	1	1	0	2.0000 kΩ	----
0	0	1	0	0	1350 °C	----
0	0	1	0	1	20.000 kΩ	----
1	1	0	1	1	AC 200.00V	LPF active
1	1	1	0	1	AC 20.000V	LPF active
1	1	1	1	1	AC 200.00mV	LPF active
1	1	1	1	0	AC 2.0000V	LPF active
1	0	0	0	0	AC 20.00A <sup>2</sup>	LPF active
1	1	1	0	0	Continuity mode	----
1	1	0	0	0	AC 200.00mA <sup>2</sup>	LPF active
1	1	0	1	0	Diode mode	----
1	1	0	0	1	ADP0 (20000) <sup>1</sup>	----
1	0	0	1	1	ADP1 (2000.0) <sup>1</sup>	----
1	0	0	0	1	AC 2000.0uA <sup>2</sup>	LPF active
1	0	1	1	1	AC 1000V	----
1	0	0	1	0	ADP2 (200.00) <sup>1</sup>	----
1	0	1	1	0	EF mode	----
1	0	1	0	0	2462 °F	----
1	0	1	0	1	ADP3 (20.000) <sup>1</sup>	----

Note:

1. When *FC5* is low, the ADP0, ADP1, ADP2, ADP3 and ADP4 modes can't display minus sign.
2. These modes could be designed for multi-meter current modes, please refer to section 1.2.



### Measurement Mode Switching (Continued)

Measurement mode depends on the logic level of *SLACDC*, *FC1*, *FC2*, *FC3*, *FC4*, *FC5* and **KEY** selection. When *FC6* is low (pulled to V-), the capacitance measurement and extra current measurement mode lists are shown below:

<i>SLACDC</i>	<i>FC1</i>	<i>FC2</i>	<i>FC3</i>	<i>FC4</i>	<i>FC5</i>	Mode	KEY selection & Remaks
X	0	0	1	1	X	20.000 nF	----
X	0	1	1	0	X	200.00 nF	----
X	0	1	0	1	X	2.0000 uF	----
X	1	0	0	1	X	20.000 uF	----
X	1	0	1	0	X	200.00 uF	----
X	1	1	0	0	X	2.0000 mF	----
X	0	1	0	0	X	20.000 mF	----
X	0	0	1	0	X	200.00 mF	----
X	1	1	1	1	X	Cap (AUTO)	----
X	1	1	1	0	X	200.00 MΩ	----
0	0	0	0	0	1	DC 2.0000A <sup>1</sup>	DCA↔ACA
0	1	0	0	0	1	DC 20.000 mA <sup>1</sup>	DCmA ↔ ACmA
0	0	0	0	1	1	DC 200.00 uA <sup>1</sup>	DCuA ↔ ACuA
1	0	0	0	0	1	AC 2.0000A <sup>1</sup>	ACA↔DCA
1	1	0	0	0	1	AC 20.000 mA <sup>12</sup>	ACmA ↔ DCmA
1	0	0	0	1	1	AC 200.00 uA <sup>12</sup>	ACuA ↔ DCuA
0	0	0	0	0	0	DC 2.0000A <sup>1</sup>	----
0	1	0	0	0	0	DC 20.000 mA <sup>12</sup>	----
0	0	0	0	1	0	DC 200.00 uA <sup>12</sup>	----
1	0	0	0	0	0	AC 2.0000A <sup>1</sup>	LPF active
1	1	0	0	0	0	AC 20.000 mA <sup>12</sup>	LPF active
1	0	0	0	1	0	AC 200.00 uA <sup>12</sup>	LPF active
0	0	1	1	1	X	Duty cycle	----
1	0	1	1	1	1	ADP4 (±2.0000) <sup>1</sup>	
1	0	1	1	1	0	ADP4 (2.0000) <sup>1</sup>	
1	1	0	1	1	X	LED	3.5V OL
0	1	0	1	1	X	Conductance	----

Note:

1. These modes could be designed for multi-meter current modes, please refer to section 1.2.



### 3. Push Function

All the enabled push functions will be reset when the measurement mode is changed when *FC1-FC5* modes are changed. The following table lists the available function versus every measurement mode.

	MMX	KEY <sup>1</sup>	VAHz	HOLD/BKLIT <sup>2</sup>	REL
Voltage mode	O	O	O	O	O
mV mode	O	O	O	O	O
Current Mode for Multimeter	O	O	O	O	O
Resistance	O	X	X	O	O
Conductance	O	X	X	O	O
Continuity	O	O	X	O	O
Diode mode	O	O	X	O	O
Frequency	X	X	O	O	X
Capacitance	O	X	X	O	O
Temperature	O	O	X	O	O
EF Mode	X	X	X	O	X
ADP mode	O	X	X	O	O

Note:

1. Push **KEY** to change AC/DC mode or °C/°F when FC5=1 or enable LPF of ACV/ACA mode when FC5=0.
2. Push **HOLD** key and last for 2 seconds will active the back light output driver (BKOUT).

### 3.1. HOLD and BKOUT output Feature

HOLD mode makes the meter stop updating the LCD panel. This mode can be nested in most of the special modes. Enabling HOLD function in automatic mode makes the meter switch to manual mode, but the range remains the same. ES289B provides a backlight output feature. To activate backlight output feature, press down the **HOLD** key and last for 2 seconds. The meter will enable output from BKOUT.

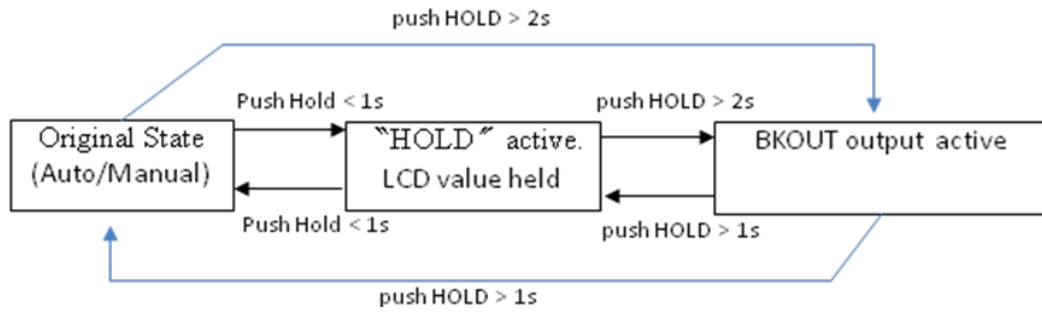

### 3.2. VAHz function

When voltage or current measurement mode is selected, the VAHz function is available. Push **VAHz** key to select this frequency measurement mode for V/A signals. The frequency is measured by auto ranging. The maximum available frequency range is 200KHz. The sensitivity of signal input is 5% full scale of signal (10mVp) in voltage or current mode typically.

Configuration	RANGE
FR1	200.00Hz
FR2	20.000KHz
FR3	200.00KHz

Note: Minimum available input frequency is 20Hz.

### 3.3. KEY

See Section “Measurement Mode Switching” for the function of this pin.

### 3.4. Max/Min + HOLD

The meter displays the maximum or minimum value of the input in Max/Min mode. When **MMX** key is pressed for the first time, the meter displays the maximum value. The meter displays the minimum value, when it is pressed again. When **MMX** key is pressed for the third time, the meter displays current value. The meter returns to normal operation if **MMX** is pressed and held for longer than one second. Pressing **HOLD** in Max/Min mode makes the meter stop updating the maximum or the minimum value.

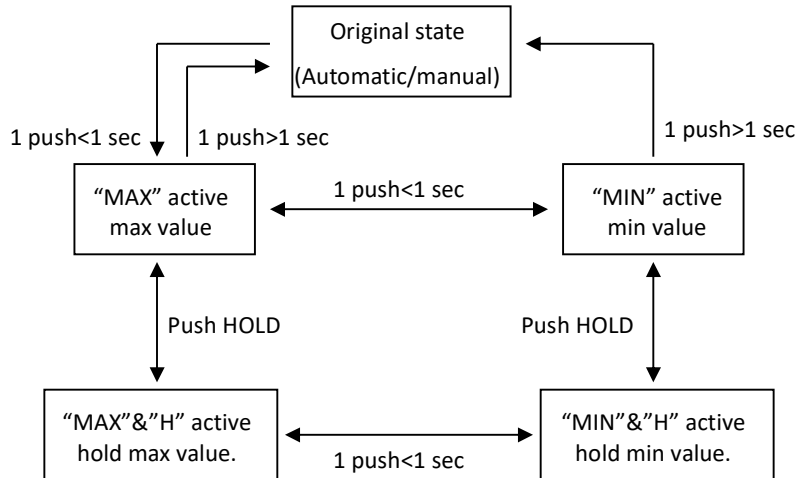

### 3.5. REL + HOLD

In REL mode, the LCD panel displays  $D_{N+K} - D_N$ , where  $N = 1, 2, 3, \dots$ ,  $D_N$  is the last value before **REL** key is pushed, and  $D_{N+K}$  is the current value. The meter returns to normal operation if **REL** is pressed again. Pressing **HOLD** in REL mode makes the meter stop updating the LCD panel.

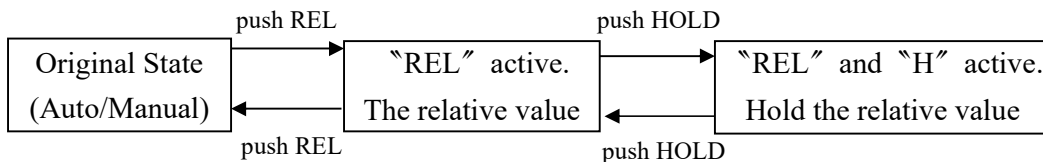

Note:

1. It's possible that relative value ( $D_{N+K} - D_N$ ) exceeds 20000 or -20000 counts. The LCD shows OL in REL mode only if  $D_N$  or  $D_{N+K}$  is more than 20000 counts.





## 5. Miscellaneous

The conditions, which the meter turns on the buzzer, include:

- (1) Changing measurement mode generates one beep.
- (2) Pressing any of the push functions generates one beep, if the function is valid.
- (3) Power on and re-power on generate one beep.
- (4) Input overflow in voltage and current mode generates one beep every 0.3 seconds (or 3.33 beeps per second.)
- (5) Hazard voltage indication is active generates one beep per second and could be disabled by *DISDGBP* pin.
- (6) Continuity(diode) check generates a continuous 2KHz beep whenever the measurement is less than  $30\Omega(30mV)$
- (7) Auto power off generates a 2KHz beep which lasts for 1.5 seconds.

The following figures show the output waveform from the BUZOUT pin.

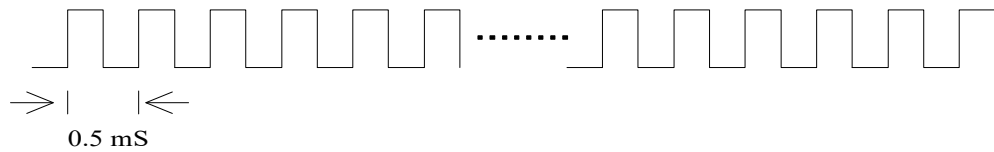

(a) Continuous 2KHz beep

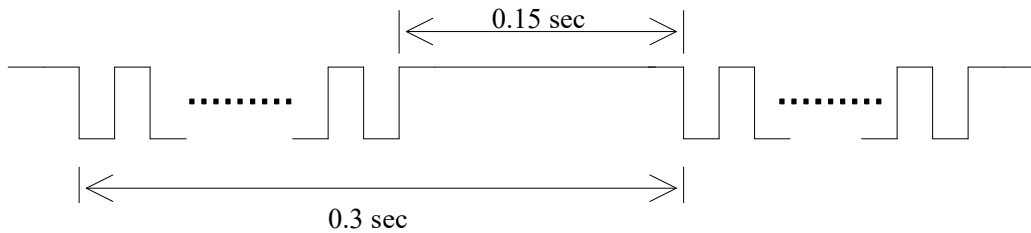

(b) 3.33 beep/sec

**3.6. LCD Panel**

	S01	S02	S03	S04	S05	S06	S07	S08	S09	S10
BP1	AUTO	LPF	5BC	HOLD	4B	REL	MAX	MIN	2A	2B
BP2	APO	AC	DP4	4A	4G	3F	3A	3B	2F	2G
BP3	DANGR	MINUS	LED	4F	4C	3E	3G	3C	2E	2C
BP4	LBAT	DC		4E	4D	DP3	3D	DP2	2D	DP1

	S11	S12	S13	S14	S15	S16	S17	S18
BP1	BUZZER	1A	DIODE	n	M	$\mu 2$	ADP0	%
BP2	1F	1B	°C	$\mu 1$	K	m2	ADP1	Pmax
BP3	1E	1G	°F	m1	$\Omega$	V	ADP2	PMIN
BP4	1D	1C	nS	F	Hz	A	ADP3	ADP4

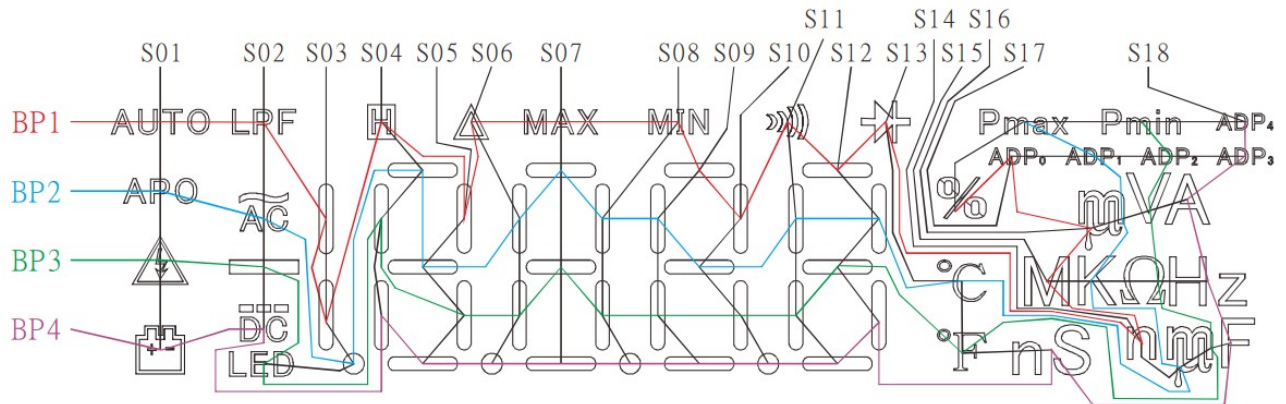

**LCD Backplane Waveform**

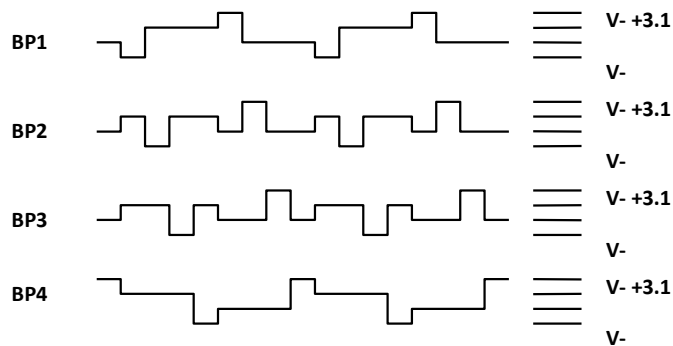



### 3.7. LCD Display On Condition

LCD Annunciator	Condition
V	In voltage measurement mode, and diode measurement mode.
A	In current measurement mode.
$\Omega$	In resistance measurement mode, and continuity mode.
F	In capacitance measurement mode.
m <sub>1</sub>	In capacitor measurement mode and the full scale range is in the order of mF.
$\mu_1$	In capacitor measurement mode and the full scale range is in the order of $\mu$ F.
n	In capacitor measurement mode and the full scale range is in the order of nF.
	In continuity check mode.
	In diode mode.
Hz	In frequency mode.
%	In duty cycle mode
ADPn	When ADP0-4 mode is active.
DC	In DC voltage or DC current mode.
AC	In AC voltage or AC current mode.
AUTO	When automatic full scale range selection is enabled. (Hz or Cap Auto mode)
HOLD	When HOLD function is enabled.
LPF	When low pass filter mode is enabled
MAX	When MAX function is enabled.
MIN	When MIN function is enabled.
REL	When Relative function is enabled
PMAX	When PEAK MAX function is enabled.
PMIN	When PEAK MIN function is enabled.
LED	In LED measurement mode.
m <sub>2</sub>	In voltage or current measurement mode and the full scale range is in the order of 10 <sup>-3</sup> .
$\mu_2$	In current measurement mode and the full scale range is in the order of $\mu$ A.
M	In measurement mode and the full scale range is in the order of M $\Omega$ or MHz
K	In measurement mode and the full scale range is in the order of K $\Omega$ or KHz
nS	In conductance measurement mode.
$^{\circ}$ C	In temperature measurement mode and when the unit is $^{\circ}$ C.
$^{\circ}$ F	In temperature measurement mode and when the unit is $^{\circ}$ F.
DANGR	When the reading is exceeding default hazardous live voltage or OL in DCV or ACV, or not proper voltage applied on Res/Cap/Diode/Hz modes, the HV warning symbol will be displayed.
APO	When auto power off function is enabled.
LBAT	When battery voltage is too low

### 4.3 Operating Timing

ES289B incorporates a dual slope ADC with four phases: ZI, AZ, INT and DINT. The timing of each phase is listed below.

(1) Voltage / Diode /ADP

Phase	High resolution
ZI	10ms
AZ	30ms
INT	100ms
DINT	210ms

(2) Current mode for multi-meter

Phase	DC / AC	DC Lower Range
ZI	10ms	10ms
AZ	30ms	30ms
INT	100ms	1000ms
DINT	210ms	210ms

(3) Continuity / Ohm / Conductance measurement:

Phase	Time	Time (200M)
ZI	10ms	10ms
AZ	30ms	20ms
INT	100ms	15ms
DINT	210ms	315ms

(4) Frequency : Every conversion takes 1.05 second. (500ms for 200Hz range)

(5) Temperature measurement:

Phase	Time
ZI	20ms
AZ	20ms
INT	500ms
DINT	360ms

Note:

1. In the frequency measurement with auto mode, if the range is changed, the internal clock rate will increase ten times and the new measurement cycle becomes 1/10 times of the original cycle until the range is stable.





2.RMS Circuit

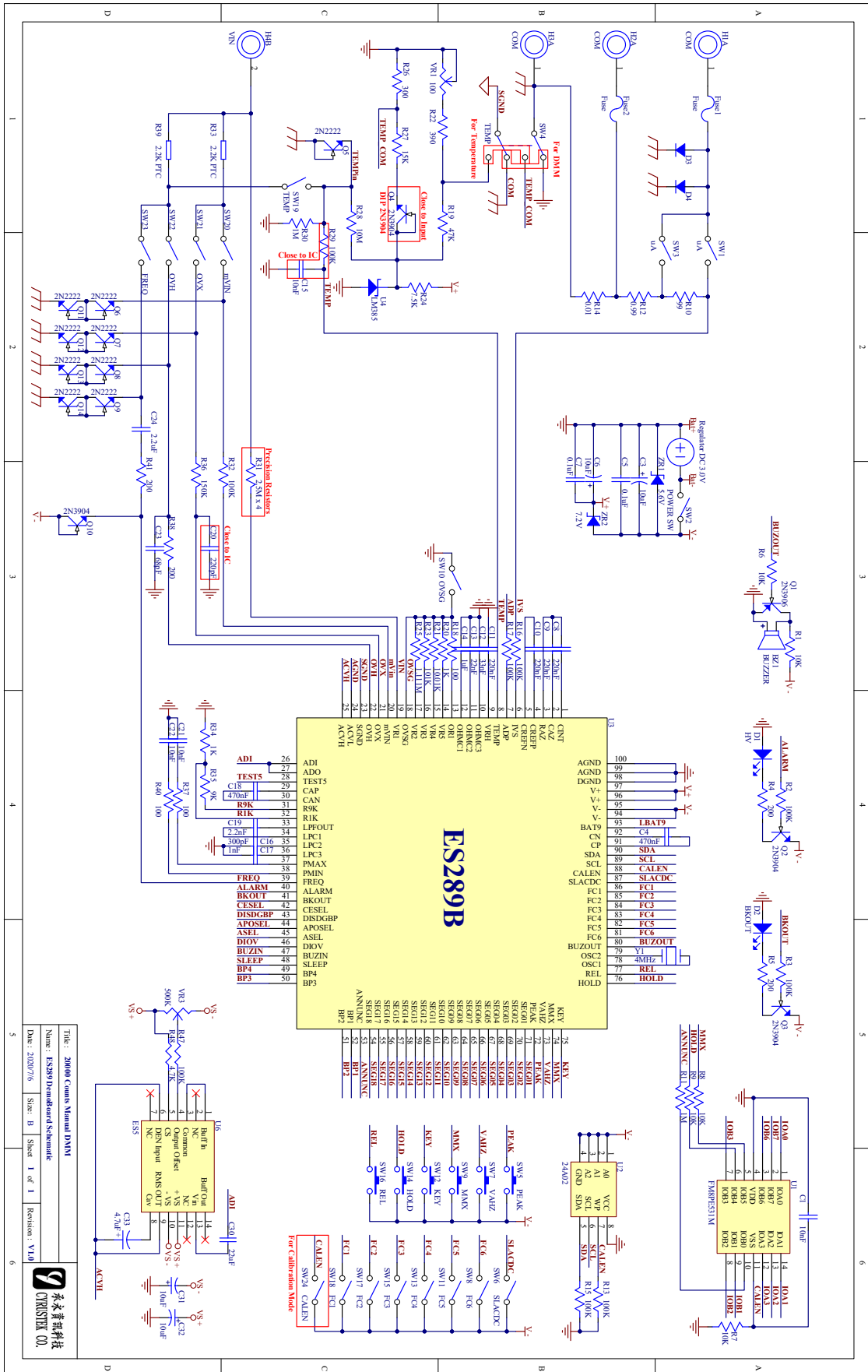

■ Package Information

■ 100L LQFP Outline drawing

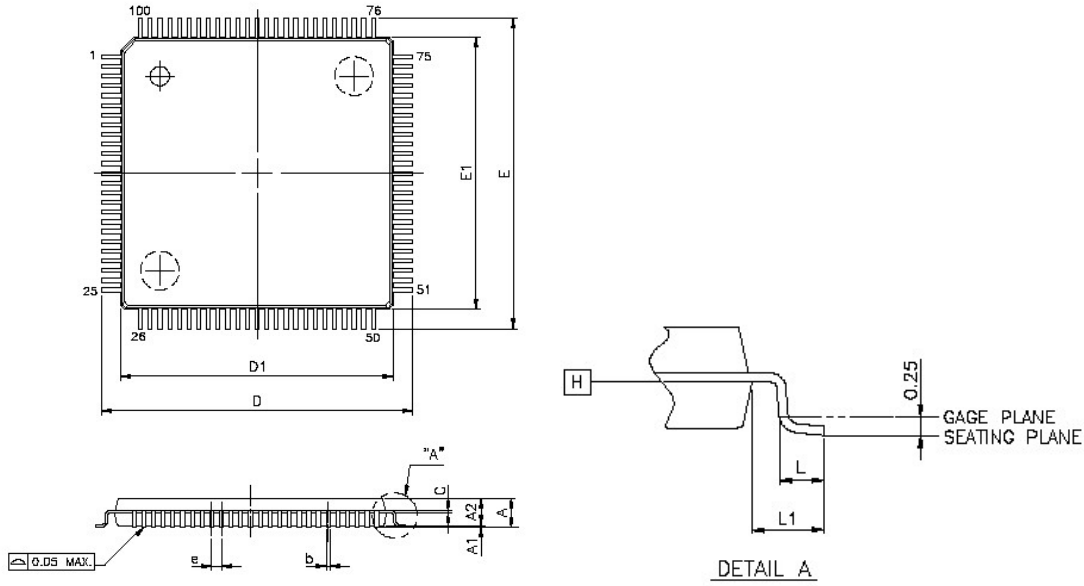

Dimension parameters

VARIATIONS (ALL DIMENSIONS SHOWN IN MM)

SYMBOLS	MIN.	NOM.	MAX.
A	--	--	1.60
A1	0.05	--	0.15
A2	1.35	1.40	1.45
b	0.17	0.20	0.27
c	0.09	0.127	0.20
D	16.00 BSC		
D1	14.00 BSC		
E	16.00 BSC		
E1	14.00 BSC		
e	0.50 BSC		
L	0.45	0.60	0.75
L1	1.00 REF		